

Webster and Hewland Gearbox Parts from Drawing A for Mk-Series (5 speed shown)

Description and Hewland No. in ()'s	Part No.	Price ea.
Rear Cover (HC204)	1410-A01	\$279.99
Reverse Stop Plunger (HC203-0)	1410-A02	\$59.99
Reverse Stop Spring (FT203-2)	1410-A03	\$5.49
Reverse Stop Plug (FT203-5)	1410-A04	\$18.99
1/4 inch Washer, 7 used for rear cover (HC202-9)	1410-A05	49c
1/4-28 Nylock Nut, 7 used for rear cover (HC202-10)	AN365-4	49c
Pinion Bearing Retaining Bolt (not for Hewland)	1410-A08	\$5.49
Washer for Pinion Bearing Bolt (FT202-7)	1410-A09	49c
Shift Interlock Plug, 2 used (FT202-8)	1410-A10	\$1.99
Short Rear Cover Stud, 5 used (HC202-5)	1410-A12	\$2.19
Long Rear Cover Stud, 2 used (HC202-6)	1410-A13	\$3.99
Selector Detent Spring, 6 used (FT202-2)	1410-A14	\$3.99
Selector Detent Ball, 6 used (FT202-1)	1410-A15	\$1.99
Selector Detent Plug, 3 used (FT202-3)	1410-A16	\$2.49
8mm Washer, 9 used for bearing carrier (FT202-7)	1410-A17	49c
8mm Nylock Nut, 9 used for bearing carrier (HC201-3A)	1410-A18	49c
Selector Bushing for Webster bearing carrier, 2 used	1410-A19W	\$3.49
Bushing for Hewland bearing carrier, 2 used (FT203-6)	1410-A19H	\$7.99
Selector Finger, Hewland manufacture (LG252)	1410-A20H	\$339.99
1st/Reverse Selector Shaft (HC246)	1410-A21	NLA
2nd/3rd Selector Shaft (HC247)	1410-A22	NLA
4th/5th Selector Shaft (HC248)	1410-A23	NLA
Shift Interlock, 2 used (HC202-4)	1410-A24	\$7.99
1st/Reverse Shifter Fork (HC249)	1410-A25	\$279.99
Reverse Fork Pinch Bolt (fits Webster fork only)	1410-A26	99c
2nd/3rd Shifter Fork (HC250)	1410-A27	\$299.99
4th/5th Shifter Fork (HC251)	1410-A28	\$269.99
Washer (lock tab washer not needed), 2 used (FT246-1)	1410-A29	99c
Self-locking Nut (no lock tab needed), 2 used (FT246-2)	1410-A30	\$4.99
Shift Fork Spacing Washer, 2 used (HC246-3)	1410-A31-1	\$3.49
Shift Fork Spacing Shim, 0.005", quantity varies	1410-A31-2	\$2.99
Shift Fork Spacing Shim, 0.010", quantity varies	1410-A31-3	\$2.99
Rear Pinion Bearing (HC229-1)	1410-A32	\$38.99
Pinion Nut, left-hand thread for Mk 8 & 9 (FT230)	1410-A34-1	\$64.99
VW Pinion Nut for Webster 300 & early Mk 4	1410-A34-2	\$9.99
Layshaft Bearing (HC234-3)	1410-A35	\$102.99
Layshaft Nut for Webster Layshaft (coarse thread)	1410-A37-1	\$109.99
Layshaft Nut for Hewland Layshaft (fine thread, FT236)	1410-A37-2	\$97.99
Layshaft Drawbolt (HC236-3)	1410-A38	\$67.99
Cotter Pin, 2 used (FT236-2) (A39)	660-6-1.50	15c
Hub Spacing Shim, 0.005", qty. varies (HC225-4)	1410-A40-1	\$2.49
Hub Spacing Shim, 0.015", qty. varies (HC225-4)	1410-A40-2	\$3.49
Reverse Slider, 4 speed, Mk 4,6,8,9 (HC8-423-1)	1410-A41/44H	\$364.99
Hewland 1st/Rev Slider, 5 sp, Mk 4,8,9 (HC4-231/HC85-231)	1410-A41/54H	\$399.99
1st/Reverse Slider for Staffs only	1410-A41/ST	\$499.00
4 speed Hub Spacer (HC84-226 when used with A42-95)	1410-A42-1	\$69.99

Description and Hewland No. in ()'s	Part No.	Price ea.
1st/Reverse Hub, Mk 4,6 & Webster (HC4-226)	1410-A42-4	\$279.99
Mk 9 4 speed 1st/Rev Hub for Mk 4 1st Gear, requires A42-1	1410-A42-9A	\$209.69
Hewland Mk 9 5 speed 1st/Reverse Hub (HC85-226)	1410-A42-95H	\$679.00
Driven Gear Needle Bearing, 4 or 5 used (FT226-1)	1410-A44	\$35.99
Dog Ring, Webster, 2 used (HC232)	1410-A47	\$209.99
Dog Ring, Hewland, 2 used (HC232)	1410-A47H	\$244.99
2nd/3rd Hub, Mk 4, Mk 6 & Webster (HC227)	1410-A48-4	\$429.99
2nd/3rd Hub, Mk 9 only (HC8-227)	1410-A48-9	\$223.99
4th/5th Hub, Mk 4, Mk 6 & Webster (HC228)	1410-A54-4	\$277.99
4th/5th Hub, Mk 9 only (HC8-228)	1410-A54-9	\$379.99
5th Gear Thrust Washer (HC229-4)	1410-A57	\$89.99
Hewland Layshaft, fine thread, Mk 4, 6, 8 & 9 (HC9-234)	1410-A58H-4	\$899.00
Hewland Reverse Driver Gear, 5 speed (HC9-238)	1410-A59H-5	\$309.99
Reverse Driver Gear Spacer, 4 speed (HC9-238-1)	1410-A59-1	\$94.99
Layshaft Spacer, 2 used (HC234-6)	1410-A61	\$32.99
Layshaft Thrust Washer (HC234-5)	1410-A66	\$72.99
Layshaft Front Bearing, 30mm OD, late Mk 8/9 (HC9-234-1)	1410-A67-1	\$19.99
Snap Ring for A67-1, 1 required (HC9-234-2)	1410-A68-1	\$3.99
Layshaft Front Bearing, 35mm OD, Mk 5 & Rhino case	1410-A67-5	\$39.99

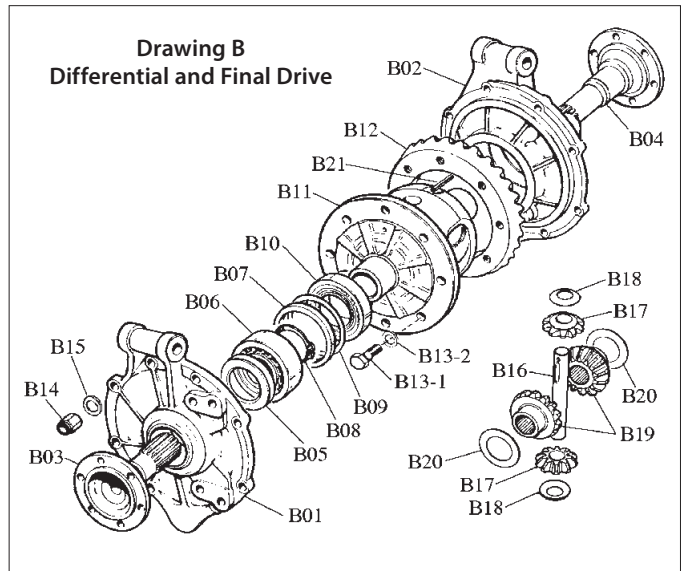

NLA = No Longer Available. These parts are listed here for reference only.

See page 150 for interchangeable gearsets.

A Hewland Part No. shown in ()'s in the above listings indicates interchangeability to the best of our knowledge.

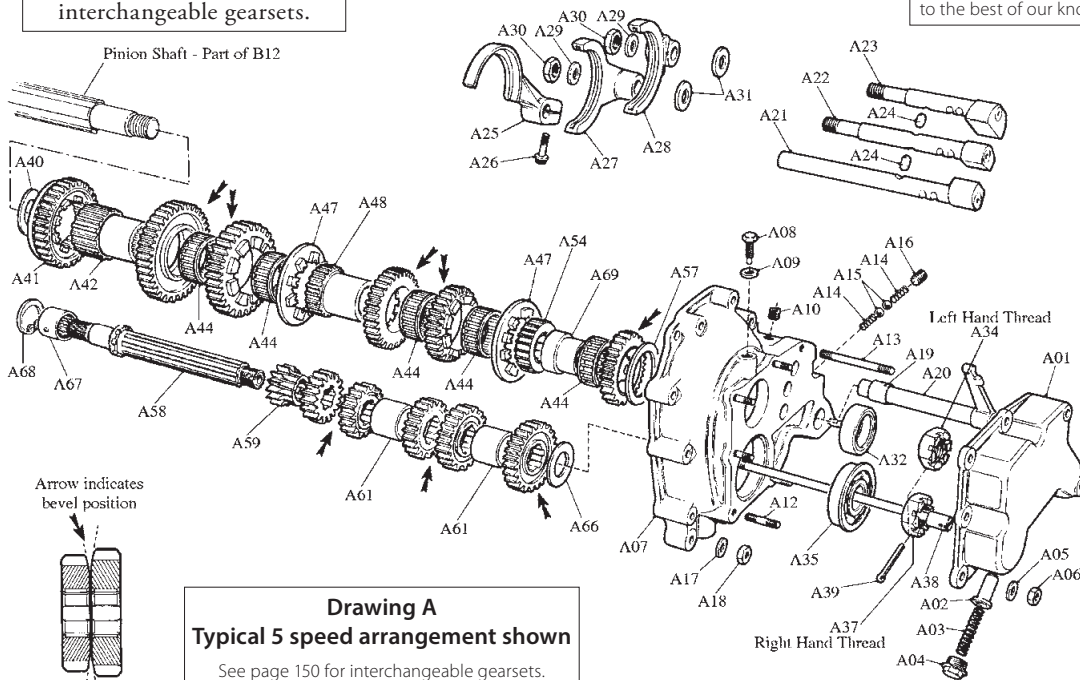

TRANSAXLE DIFFERENTIAL