

Brake Master Cylinders

Girling Master Cylinders

Girling Aluminum Master Cylinders with Small (1.75" dia.) Integral Reservoir These reliable master cylinders feature a rear facing outlet port that is ideal for cars with limited space in front of the master cylinder. All sizes come complete with a pushrod that has a 5/16-24 thread. The lengths of the pushrods vary but are usually 3.75 to 4.00" long as measured from the mounting flange. Has a 3/8-24 outlet port. See next page for rebuild kits.

- Girling Master Cylinder with integral reservoir - 5/8" Bore Part No. 3500-62 \$114.99
- Girling Master Cylinder with integral reservoir - .70" Bore Part No. 3500-70 \$114.99
- Girling Master Cylinder with integral reservoir - 3/4" Bore Part No. 3500-75 \$114.99
- Reservoir Extension for above master cylinders (with seal & cap) Part No. 3560 \$23.49
When installing the extension, be sure to position the seal below the flange on the extension.
- Aluminum Cap for small (1.75" dia.) integral reservoir (without gasket) Part No. 3549 \$7.49
- Plastic Cap for small (1.75" dia.) integral reservoir Part No. 3550 \$6.49
- Replacement Cap for large (2.5" dia.) integral reservoir Part No. 3553 \$14.99
(We don't sell the large reservoir type of Girling Master Cylinder — just the caps.)
- Girling Pushrod, 5/16-24 thread, 3.3 inch overall length Part No. 3554-3.3 \$16.99
- Girling Pushrod, 5/16-24 thread, 3.7 inch overall length Part No. 3554-3.7 \$16.99
- Steel Clevis for pushrod, 5/16" hole, 5/16" slot, 1.8" overall length Part No. 3576 \$15.79

Girling Remote Master Cylinders without Reservoir Same as above but without an integral reservoir. Designed for connection to a remotely mounted reservoir or for attachment of a separate reservoir directly to the master cylinder. Has a 7/16-20 female inlet port. All sizes come complete with a pushrod that has a 5/16-24 thread. The lengths of the pushrods vary but are usually 3.75 to 4.00" long as measured from the mounting flange. See above for replacement pushrods and optional clevis. See next page for rebuild kits.

- Girling Remote Reservoir Master Cylinder - 5/8" Bore (alum.) Part No. 3502-62 \$99.99
- Girling Remote Reservoir Master Cylinder - .70" Bore (alum.) Part No. 3502-70 \$99.99
- Girling Remote Reservoir Master Cylinder - 3/4" Bore (alum.) Part No. 3502-75 \$99.99
- Banjo Style Barbed inlet fitting for 5/16" I.D. hose Part No. 3219 \$54.99
- Barbed inlet fitting for 5/16" I.D. hose (see below for seal & hose) Part No. 3207 \$22.99
- 7/16" I.D. Aluminum Stat-O-Seal for above adapter fitting Part No. 3245-7/16 \$1.49
- 5/16" I.D. hose for connecting remote reservoirs, per foot Part No. 3575-Foot \$2.99

All of the master cylinders that we stock have the standard vertical mounting flange with 2.25" hole spacing.

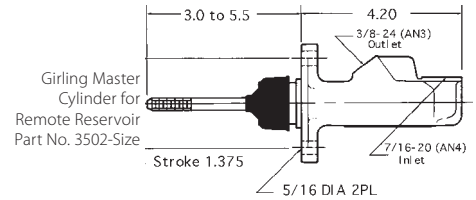
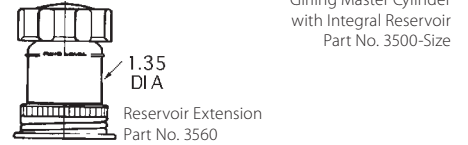
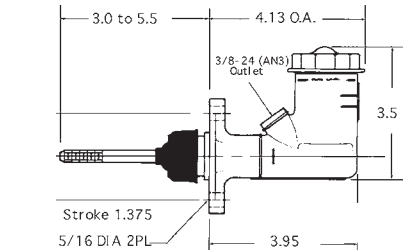

Tilton 74 Series Master Cylinder Kits and Replacement Parts

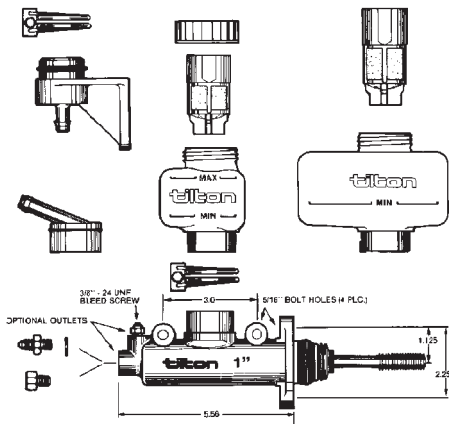

Tilton 74 Series Master Cylinder Kit Part No. 3505-Size

These versatile kits are interchangeable with most racing master cylinders. Kit includes both large (10.7 oz.) and small (4.0 oz.) reservoir that can be mounted directly on the cylinder or remotely mounted using the bracket, fittings and hose furnished with the kit. The aluminum body includes bosses for side or flange mounting. Dual outlets are provided along with a bleed screw and adapters for AN3 and 3/16 inch inverted flare brake lines. All sizes come complete with a pushrod that has a 5/16-24 thread. The lengths of the pushrods are about 4.24" long as measured from the mounting flange. See next page for rebuild kits.

- Tilton 74 Series Master Cylinder Kit - 5/8" Bore Part No. 3505-62 \$82.99
- Tilton 74 Series Master Cylinder Kit - .70" Bore Part No. 3505-70 \$82.99
- Tilton 74 Series Master Cylinder Kit - 3/4" Bore Part No. 3505-75 \$82.99
- Tilton 74 Series Master Cylinder Kit - 13/16" Bore Part No. 3505-81 \$82.99
- Tilton 74 Series Master Cylinder Kit - 7/8" Bore Part No. 3505-87 \$82.99
- Tilton 74 Series Master Cylinder Kit - 15/16" Bore Part No. 3505-94 \$82.99
- Tilton 74 Series Master Cylinder Kit - 1.0" Bore Part No. 3505-1.00 \$82.99
- Tilton 74 Series Master Cylinder Kit - 1 1/8" Bore Part No. 3505-1.125 \$82.99

Replacement Parts for Tilton 74 Series and 75 Series Master Cylinders:

- Baffled Threaded Cap (leak-proof during cornering) Part No. 3564 \$5.99
 - Small Reservoir, 4 oz (threaded cap not included) Part No. 3558-Small \$7.99
 - Medium Reservoir, 6.8 oz (threaded cap not included) Part No. 3558-Med \$7.99
 - Large Reservoir, 10.7 oz (threaded cap not included) Part No. 3558-Large \$7.99
 - Filter Screen for Small Tilton Reservoir Part No. 3559-Small \$4.49
 - Filter Screen for Medium and Large Tilton Reservoir Part No. 3559-Large \$4.49
 - Remote Reservoir Mounting Bracket Part No. 3557 \$8.99
 - O-Ring for Remote Reservoir Mounting Bracket Part No. 3578 \$1.49
 - Remote Inlet Fitting (mounts on master cylinder) Part No. 3563 \$3.99
 - Clamp for Reservoir or Remote Inlet Part No. 3577 \$1.99
 - O-Ring for Master Cylinder Inlet Neck Part No. 3556 \$1.49
- For replacement pushrods and optional clevis, see Lockheed section above.

Replacement Parts for Lockheed Master Cylinders

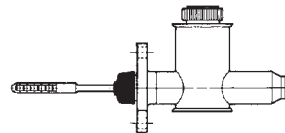

This Can Style AP/Lockheed Master Cylinder is OBSOLETE. However, some replacement parts are still available.

See next page for rebuild kits.

- Lockheed Replacement Cap Part No. 3551 \$4.99
 - Replacement O-Ring Seal for Extension Part No. 3562 99¢
 - Push-Rod for Lockheed or Tilton, 4.5" overall length Part No. 3555-4.5 \$12.49
 - Push-Rod for Lockheed or Tilton, 6.2" overall length Part No. 3555-6.2 \$23.99
- Both of the above push-rods have a 5/16-24 thread.
- Steel Clevis for push-rod, 5/16" hole, 5/16" slot, 1.8" long Part No. 3576 \$15.79

Tilton 75 Series Compact Master Cylinder Kits



Similar to 74 Series master cylinders but only 3.2" from mounting surface to outlet port. Provides a full 1.1" stroke despite the compact size. Kit includes both small (4 oz) and medium (6.8 oz) reservoirs. See left column of this page and next page for replacement parts.

- Tilton 75 Series Compact Master Cylinder Kit - 5/8" Bore Part No. 3506-62 \$104.99
- Tilton 75 Series Compact Master Cylinder Kit - .70" Bore Part No. 3506-70 \$104.99
- Tilton 75 Series Compact Master Cylinder Kit - 3/4" Bore Part No. 3506-75 \$104.99
- Tilton 75 Series Compact Master Cylinder Kit - 13/16" Bore Part No. 3506-81 \$104.99
- Tilton 75 Series Compact Master Cylinder Kit - 7/8" Bore Part No. 3506-87 \$104.99
- Tilton 75 Series Compact Master Cylinder Kit - 15/16" Bore Part No. 3506-94 \$104.99
- Tilton 75 Series Compact Master Cylinder Kit - 1.0" Bore Part No. 3506-1.00 \$104.99
- Tilton 75 Series Compact Master Cylinder Kit - 1 1/8" Bore Part No. 3506-1.125 \$104.99

Tilton 76 Series Compact Master Cylinders



Based on the popular 75 series short-body master cylinder (shown above), the Tilton 76 series master cylinder features a threaded inlet port designed to accept 4AN fittings and direct screw-on reservoirs instead of Tilton reservoirs. Uses the same rebuild kit as the 75 series (see next page).

- Tilton 76 Series Compact Master Cylinder - 5/8" Bore Part No. 3507-62 \$124.99
- Tilton 76 Series Compact Master Cylinder - .70" Bore Part No. 3507-70 \$124.99
- Tilton 76 Series Compact Master Cylinder - 3/4" Bore Part No. 3507-75 \$124.99
- Tilton 76 Series Compact Master Cylinder - 13/16" Bore Part No. 3507-81 \$124.99
- Tilton 76 Series Compact Master Cylinder - 7/8" Bore Part No. 3507-87 \$124.99
- Tilton 76 Series Compact Master Cylinder - 15/16" Bore Part No. 3507-94 \$124.99
- Tilton 76 Series Compact Master Cylinder - 1.0" Bore Part No. 3507-1.00 \$124.99