

Ford 1.6L Engine Parts

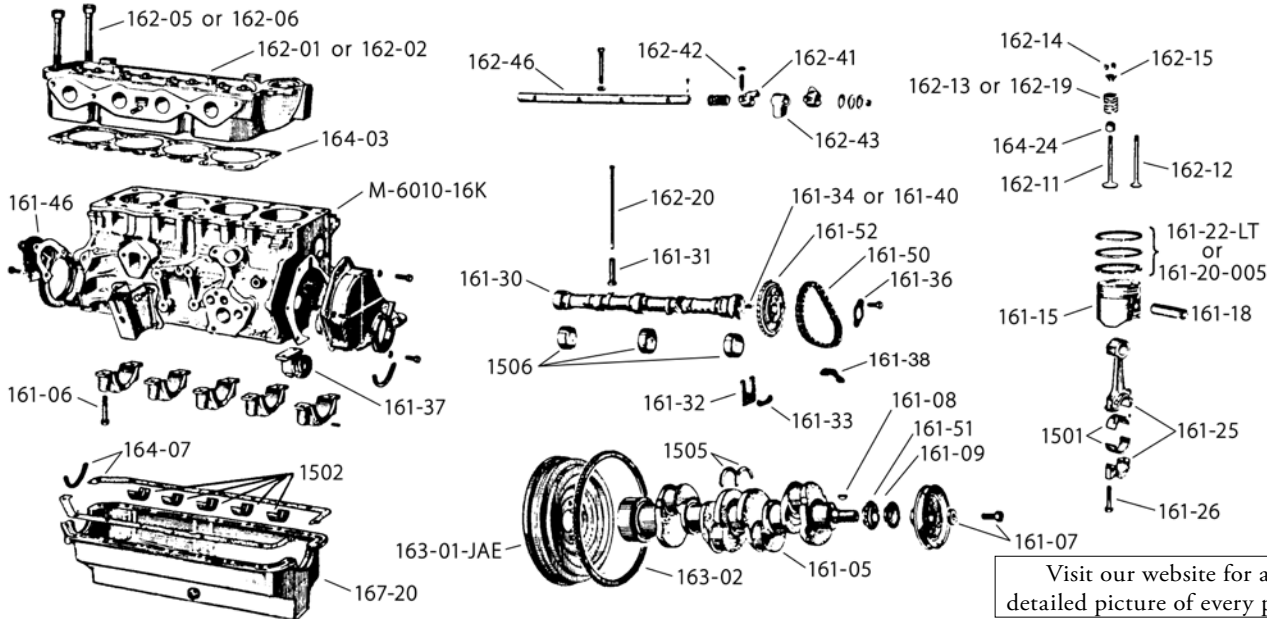

Visit our website for a detailed picture of every part!

Ford 1.6L Engine Parts, Bottom End

Description	Part No.	Price
NEW FF1600 Engine Block by Ford Racing	M-6010-16K	\$1,439.00
<i>Brand-new, SCCA-legal "711M" block. Cylinders are unfinished; final machining required.</i>		
Oil Gallery Plug, Large	161-03-Lg	\$8.99
Oil Gallery Plug, Small	161-03-Sm	\$7.99
New SCAT Crankshaft, drop-in (modified counterweights)	161-05-SCAT-CCW	\$859.00
Main Bearing Cap Bolt	161-06	\$5.99
Crankshaft Front Bolt	161-07-Bolt	\$4.29
Crankshaft Front Washer	161-07-Washer	\$4.69
Crankshaft Woodruff Key	161-08	\$13.99
Crankshaft Oil Slinger	161-09	\$22.99
Pilot Bearing for Clutch Shaft	161-10	\$23.99
Oil Pump Gear	167-15	\$99.99
Pin for Oil Pump Gear	161-12	\$1.59
Set of 4 Forged Pistons with Spirolocs (no Rings or Pins)	161-15-Forged	\$679.00
Set of 4 Forged Pistons w/Spirolocs, 0.005" Oversize	161-15-005	\$669.00
Wrist Pin, each	161-18	\$15.99
Spiral Lock Wrist Pin Retainer, each	161-19-Sprl	\$1.29
<i>These spiral retainers can't work loose like the stock circlips can</i>		
Piston Ring Set for Standard-Size Pistons (stock or forged)	161-20-Std	\$91.99
Piston Ring Set for 0.005" Oversize Forged Pistons	161-20-005	\$154.99
New SCAT Connecting Rods with ARP Bolts, set of 4	161-25-SCAT	\$599.00
Connecting Rod Bolt, Standard, each	161-26-Std	\$7.99
Connecting Rod Bolt, ARP 12 point, each	161-26-12pt	\$20.49
Connecting Rod Bolt, 12 point, ea. 0.008 oz heavier than above	161-26-12pt Hvy	\$16.99
Alignment Dowel for Connecting Rod large end cap	161-27	\$2.99
New Stock Camshaft by Formula Ford International	161-30-Stk	\$419.99
Camshaft and Lifter Lubricant, 4 oz., Ford Motorsport	3312	\$8.49
Cam Follower, 0.436 dia. (original Cortina), each	161-31-.436	\$26.99
Cam Follower, 0.516 dia. (Uprated engine), each	161-31-.516	\$21.99
Camshaft Thrust Plate	161-32	\$62.99
Lock Tab for Cam Thrust Plate Bolts	161-33	\$7.49
Dowel, Camshaft to Sprocket, stock	161-34	\$6.49
Offset Cam Dowel, specify 1, 2, 3, 4, 5, 6, 7, 8, or 9° offset	161-40-()	\$9.99
Lock Tab for Cam Sprocket	161-36	\$11.99
Timing Chain Tensioner	161-37	\$149.99
Chain Rubbing Block	161-38	\$31.99
Timing Chain Tensioner and Pad Kit	161-41-Kit	\$159.99
Rear Crankshaft Cover, used	161-46	\$89.99
Timing Chain	161-50	\$119.99
Crankshaft Timing Chain Sprocket	161-51	\$109.99
Camshaft Timing Chain Sprocket	161-52	\$114.99
Dowel, Block to Head	161-55	\$4.99
Dowel, Block to Bell Housing	161-56	\$8.49
Small Freeze Plug for block, 1.62" dia.	161-61-1.62	\$7.99
Block Plug for breather hole above fuel pump, 0.9375" dia.	161-61-9375	\$1.49
Mechanical Fuel Pump, clockable top, 6AN male fittings	161-79	\$89.99
Mechanical Fuel Pump, standard (fixed push-on fittings)	161-80	\$329.99
Water Pump with stock pulley flange	161-82	\$139.99
44 tooth Gilmer Pulley for Water Pump	166-02-.62	\$125.99
Crank Scraper	161-90	\$24.99

To keep your Formula Ford 1600 engine competitive *and legal*, we offer stock engine parts from **Ford Motor Company**; parts made to Ford OEM specifications by **Formula Ford International**; and race prepared parts from **Ivey Engines**, **SCAT Crankshafts**, and **CP Pistons**. All of the parts listed here are for the "Uprated" version of the Formula Ford 1600 engine. We don't carry any parts for the "Cortina" version although most parts are interchangeable (except for pistons, rings, head, valves, intake manifold, and carb).

See page 65 for ignition parts.
See page 71 for dry sump parts.
See page 146 for flywheel and clutch parts.

Ford 1.6L Engine Parts, Top End

Description	Part No.	Price
Unmodified Aluminum Cylinder Head, bare	162-01-Alum	\$939.00
<i>Ready for prep work. Does not include valves, springs, or rocker shaft assembly.</i>		
Ivey Prepared Aluminum Cylinder Head	162-02-Prep	\$2,599.00
<i>Includes valves and springs. Does not include the rocker shaft assembly.</i>		
Cylinder Head Bolt, Long	162-05	\$18.99
Cylinder Head Bolt, Short	162-06	\$15.99
Head Bolt Washers for aluminum head, set of 10	APR200-8532	\$8.52
Intake Manifold Bolts, flange head, set of 5 with washers	ARP622-1250	\$13.15
Carburetor Mounting Stud for Intake Manifold	162-09	\$2.29
Stock Intake Manifold, used	162-10-Stk	\$479.99
Intake Valve	162-11	\$24.79
Exhaust Valve	162-12	\$37.99
Heavy-Duty Valve Spring Set	162-13	\$79.99
Formula Ford Valve Spring Set (Ivey), for FF1600-legal cam only	162-19	\$102.99
Valve Keeper, each	162-14	\$3.99
Valve Spring Retainer	162-15	\$19.99
Bronze Valve Guide, .439 dia, .420 seal dia.	162-17	\$11.49
Cast Aluminum Valve Cover by Ford Racing	M-6582-16K	\$169.99
<i>This finned valve cover uses the stock cork gasket (sold separately). You must drill the cover for a breather outlet. As-cast finish is ready for sanding and polishing or painting.</i>		
Valve Cover Hold-downs, per set	162-33	\$7.99
Rocker Arm Adjuster, late style (self-locking)	162-42	\$32.99
Rocker Stand, Aftermarket Aluminum, Set of 4	162-43-Alum	\$149.99
Rocker Stand Flat Washer	162-45	79¢
Rocker Shaft Only	162-46	\$119.99
Rocker Shaft Washer, flat	162-48	79¢
Rocker Shaft Washer, wavy	162-49	79¢

Stage 8 Locking Header Bolts for Ford 1.6L

Forget safety wire! The Stage 8 system uses a specially designed 12-point bolt with a clip-on locking retainer. The header pipe prevents the retainer from turning, which stops the bolt from loosening. Easily removed for service and reusable. Set of 8 bolts, tabs, and retainer clips is more than enough for one Ford 1600 engine (you get 2 spares of each).
Stage 8 Locking Header Bolt Set for 1.6L Ford.....ST8-6100.....\$44.99