

Tilton Master Cylinders

Tilton 74-Series Master Cylinder Kits and Replacement Parts

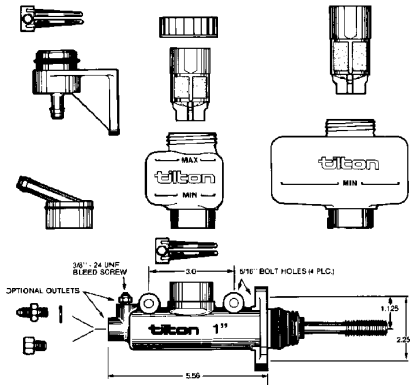

Tilton 74-Series Master Cylinder Kit Part No. 3505-Size

Kit includes large and small fluid reservoirs, remote reservoir mounting bracket, remote inlet fitting, fluid inlet hose, and outlet adapters for 3AN and 3/8-24 inverted flare brake lines.

These very complete kits include both a large (10.7 oz.) and a small (4.0 oz.) reservoir that can be mounted directly on the cylinder or remotely. The remote bracket, fittings and hose are also furnished with the kit. The aluminum body includes bosses for side or flange mounting. Dual outlets are provided along with a bleed screw and adapters for AN3 and 3/16 inch inverted flare brake lines. All sizes include a pushrod with 5/16-24 threads. The pushrod is about 4.24" long as measured from the mounting flange.

- Tilton 74-Series Master Cylinder Kit - 5/8" Bore Part No. 3505-.62 \$75.65
- Tilton 74-Series Master Cylinder Kit - .70" Bore Part No. 3505-.70 \$80.75
- Tilton 74-Series Master Cylinder Kit - 3/4" Bore Part No. 3505-.75 \$75.65
- Tilton 74-Series Master Cylinder Kit - 13/16" Bore Part No. 3505-.81 \$80.75
- Tilton 74-Series Master Cylinder Kit - 7/8" Bore Part No. 3505-.87 \$75.65
- Tilton 74-Series Master Cylinder Kit - 1.0" Bore Part No. 3505-1.00 \$75.65
- Tilton 74-Series Master Cylinder Kit - 1 1/8" Bore Part No. 3505-1.125 \$75.65

Replacement Parts for Tilton 74-Series and 75-Series Master Cylinders:

- Baffled Threaded Cap (leak-proof during cornering) Part No. 3564 \$5.10
- Small Reservoir, 4 oz (threaded cap not included) Part No. 3558-Small \$6.80
- Medium Reservoir, 6.8 oz (threaded cap not included) Part No. 3558-Med. \$6.80
- Large Reservoir, 10.7 oz (threaded cap not included) Part No. 3558-Large \$6.80
- Filter Screen for Small Tilton Reservoir Part No. 3559-Small \$3.82
- Filter Screen for Medium or Large Tilton Reservoir Part No. 3559-Large \$3.82
- Remote Reservoir Mounting Bracket Part No. 3557 \$7.65
- O-Ring for Remote Reservoir Mounting Bracket Part No. 3578 \$1.27
- Remote Inlet Fitting (mounts on master cylinder) Part No. 3563 \$3.40
- Clamp for Reservoir or Remote Inlet Part No. 3577 \$1.70
- O-Ring for Master Cylinder Inlet Neck Part No. 3556 \$1.27
- Tilton Pushrod, 5/16-24 thread, 4.5" long Part No. 3555-4.5 \$15.99
- Tilton Pushrod, 5/16-24 thread, 6.2" long Part No. 3555-6.2 \$31.99
- Tilton Pushrod, 5/16-24 thread, 7.0" long Part No. 3555-7.0 \$25.99

Tilton 78-Series Rear-Pivoting Master Cylinders



The **Tilton 78-Series Master Cylinders** pivot at the rear of the cylinder body to keep the pushrod parallel to the bore throughout the stroke. The cut-off port location is fully tunable so you can alter the pedal free play to suit your individual driving style. Despite the compact size (3.4" long), they still feature a full 1.1" stroke. The pushrod is a larger diameter than on conventional master cylinders, with 3/8-24 threads. The outlet port has 3AN (3/8-24) female threads; the inlet port has -6 (9/16-18) female threads with a flat face for a crush washer seal (inlet fittings sold separately below).

- Tilton 78-Series Master Cylinder, 5/8" Bore Part No. TE 78-625 \$208.25
- Tilton 78-Series Master Cylinder, .70" Bore Part No. TE 78-700 \$208.25
- Tilton 78-Series Master Cylinder, 3/4" Bore Part No. TE 78-750 \$208.25
- Tilton 78-Series Master Cylinder, 13/16" Bore Part No. TE 78-812 \$208.25
- Tilton 78-Series Master Cylinder, 7/8" Bore Part No. TE 78-875 \$208.25
- Tilton 78-Series Master Cylinder, 15/16" Bore Part No. TE 78-937 \$208.25
- Tilton 78-Series Master Cylinder, 1" Bore Part No. TE 78-1000 \$208.25

Note: These master cylinders will not work with conventional bias bars or pedal sets.

Inlet Fittings for Tilton 78-Series Master Cylinders

- Tilton 78-Series master cylinders have a female -6 (9/16-18) brake fluid inlet port.
- Straight Inlet Adapter, 6AN to 4AN Part No. TE 77-015 \$12.75
 - Banjo Adapter, 4AN male, accepts 9/16" banjo bolt Part No. 3265-46 \$38.99
 - Banjo Bolt, 9/16-18 Part No. 3242-026 \$15.49
 - Aluminum Crush Washers, 9/16" ID, pack of 5 Part No. 3278-06 \$2.39

Rebuild Kits for Tilton 78-Series Master Cylinders

- Tilton 78-Series Rebuild Kit Part No. TE 78-(xxx)RK. \$34.00
- Replace (xxx) with bore size when ordering.

Tilton 75-Series Compact Master Cylinder Kits



These compact cylinders have all of the same specifications of the full-size 74-Series master cylinders, but they measure only 3.2" from mounting surface to outlet port. Provides a full 1.1" stroke despite the compact size. Kit includes both small (4 oz) and medium (6.8 oz) reservoirs, plus all the remote mounting parts included with the 74-Series.

- Tilton 75-Series Compact Master Cylinder Kit - 5/8" Bore .. Part No. 3506-.62 \$92.65
- Tilton 75-Series Compact Master Cylinder Kit - .70" Bore .. Part No. 3506-.70 \$97.75
- Tilton 75-Series Compact Master Cylinder Kit - 3/4" Bore .. Part No. 3506-.75 \$92.65
- Tilton 75-Series Compact Master Cylinder Kit - 13/16" Bore Part No. 3506-.81 \$97.75
- Tilton 75-Series Compact Master Cylinder Kit - 7/8" Bore .. Part No. 3506-.87 \$92.65
- Tilton 75-Series Compact Master Cylinder Kit - 1.0" Bore .. Part No. 3506-1.00 \$92.65

Tilton 76-Series Compact Master Cylinders



Based on the popular 75-Series short-body master cylinder (shown above), the Tilton 76-Series master cylinder features a threaded inlet port designed to accept 4AN fittings and direct screw-on reservoirs instead of Tilton reservoirs. Uses the same rebuild kit as the 75-Series (see below).

- Tilton 76-Series Compact Master Cylinder - 5/8" Bore Part No. 3507-.62 \$106.25
- Tilton 76-Series Compact Master Cylinder - .70" Bore Part No. 3507-.70 \$114.75
- Tilton 76-Series Compact Master Cylinder - 3/4" Bore Part No. 3507-.75 \$106.25
- Tilton 76-Series Compact Master Cylinder - 13/16" Bore Part No. 3507-.81 \$114.75
- Tilton 76-Series Compact Master Cylinder - 7/8" Bore Part No. 3507-.87 \$106.25

Tilton Master Cylinder Rebuild Kits

Tilton master cylinder rebuild kits include a replacement piston and return spring for a thorough rebuild. Be sure to order the correct type for your master cylinder: The full-size 74-Series (at left) or the compact 75- or 76-Series (above). Tilton casts the bore size in the side of the cylinder for easy reference.

- Rebuild Kit for Tilton 74-Series Master Cylinders Part No. 3509-xx \$21.25
- Fits Tilton **74-Series** Master Cylinders (our Part No. 3505-xx). Specify bore size: .62, .70, .75, .81, .87, .94, 1.0 or 1.125.
- Rebuild Kit for Tilton Compact Master Cylinders Part No. 3510-xx \$21.25
- Fits Tilton **75-Series** (our Part No. 3506-xx) and Tilton **76-Series** (our Part No. 3507-xx) Master Cylinders. Specify bore size: .62, .70, .75, .81, .87, 1.0 or 1.125.

Tilton 900-Series Pedal Assembly



Right: Tilton 900-Series Floor-Mount Pedal Assembly Part No. TE 72-903 Shown with 77-Series Master Cylinders Part No. TE 77-xxx (sold separately)



Brake Bias Bar for Tilton 77-Series Master Cylinders Part No. TE 72-280

The Tilton **900-Series Pedal Assembly** is designed to work with the Tilton 77-Series rear-pivoting master cylinders (sold separately). This combination minimizes friction and lost motion to provide the most consistent and repeatable braking possible. The billet aluminum pedals pivot on ball bearings for smooth motion without any side play. The special pivoting bias bar (included) bolts in place on the brake pedal. It can be mounted in 8 different positions to adjust pedal ratio quickly from 4.52:1 to 5.80:1. Needle bearing pivots in the bias bar prevent bias creep and migration found in conventional spherical bearing bias bars. The pedal pads are also adjustable vertically and horizontally for best fit and easy heel-and-toe downshifting. Master cylinders sold separately.

- Tilton 900-Series Pedal Assembly, Floor-Mount Part No. TE 72-903 \$2,082.50
 - Brake Bias Bar Remote Adjuster Cable Part No. 3526 \$63.75
- Allows quick bias bar adjustment from the cockpit. Six foot cable can be shortened to suit your installation. Includes detented knob.
- Throttle Linkage for Floor-Mount Pedal Assembly Part No. TE 72-791 \$123.25
- This adjustable bellcrank is used in many front-engine applications to convert the forward push on the throttle to a rearward pull. Not used on rear-engine vehicles.
- Bias Bar only for Tilton 77-Series Masters Part No. TE 72-280 \$531.25
- Pivoting bias bar accepts the 3/8-24 pushrods on the Tilton 77-Series master cylinders. It will not work with conventional master cylinders with 5/16-24 threaded pushrods. This version has 3 sets of mounting bolt holes for adjustability.

BRAKES