

## Ford 2.0L Engine Parts

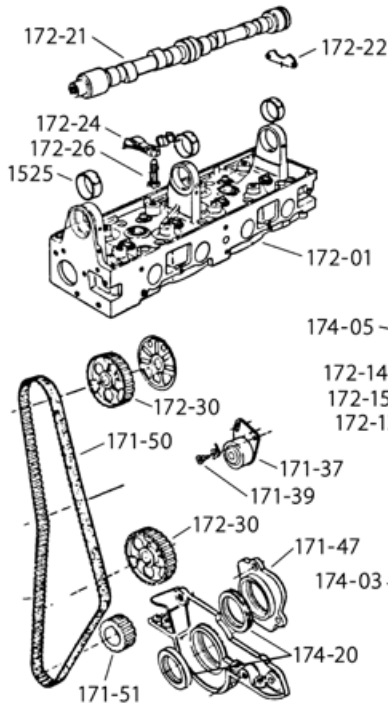

We carry stock engine parts as well as race prepared components from Ivey Engines.

See page 65 for ignition parts.  
See page 70 for dry sump parts.  
See page 146 for flywheel and clutch parts.

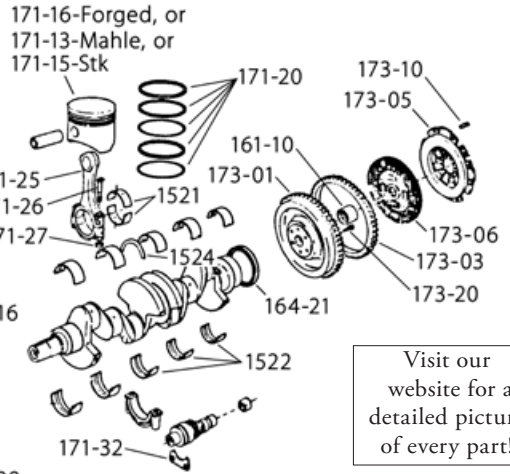

Visit our website for a detailed picture of every part!

### Ford 2.0L Engine Parts, Bottom End

Description	Part No.	Price
Main Bearing Cap Bolt	171-06	\$7.99
Crankshaft Front Bolt	171-07-Bolt	\$4.99
Main Bearing Cap Dowel, short	171-09	\$1.49
Pilot Bearing for Clutch Shaft (same as 1.6L engine)	161-10	\$23.99
Set of 4 Forged CP Pistons with Wrist Pins and Clips	171-16-Forged	\$699.00
<i>These forged pistons do not include piston rings.</i>		
Mahle '85 Piston with Wrist Pin, WITHOUT rings, each	171-13-Mahle	\$124.99
Stock '85 AE Piston with Rings and Wrist Pin, each	171-15-Stk	\$159.99
Ivey Prepared Piston Ring Set for Forged pistons (for 4)	171-20-JE	\$179.99
<i>These rings fit CP or JE forged pistons only. They do not fit Ford AE or Mahle pistons.</i>		
Connecting Rod Bolt, Standard	171-26-Std	\$5.89
Connecting Rod Bolt, Competition, SPS, each	171-26-Comp	\$15.99
Connecting Rod Nut	171-27	\$6.99
Heavy-Duty Competition Rod Bolt and Nut Set, 16 piece kit	171-28-Set	\$41.87
<i>Fits stock Ford rods only (not Ford Motorsport/Oliver rods).</i>		
Auxiliary Shaft Front Bearing	171-31-Front	\$29.99
Auxiliary Shaft Thrust Plate	171-32	\$11.99
Timing Belt Tensioner	171-37	\$199.99
Tensioner Spring Retaining Bolt	171-39	\$21.49
Auxiliary Shaft Seal Housing	171-47	\$18.99
Timing Belt (camshaft drive belt)	171-50	\$46.99
Crankshaft Timing Belt Pulley	171-51	\$99.99
Crankshaft to Pulley Key, 1 piece (late style)	171-52-Late	\$3.69
Dowel, Block to Bell Housing	171-55	\$6.79
Thermostat O-Ring Seal (square cross-section quad-ring)	171-57-Seal	\$5.99
Thermostat Retaining Clip	171-57-Clip	\$6.99
48mm (1.89 inch) Freeze Plug, one required	171-60	\$9.99
Mechanical Fuel Pump, adjustable fitting orientation	171-79	\$94.99
<i>Fittings are adjustable in 60° increments. See website for detailed photo.</i>		
Mechanical Fuel Pump, standard (fixed fittings)	171-80	\$169.99
Fuel Pump Push Rod	171-81	\$36.99
Fuel Pump Block off Plate, for electric pump	174-14	\$13.99
44 tooth Gilmer Pulley for Water Pump	166-02-62	\$125.99
Crank Scraper	171-90	\$24.99

Visit our website for a detailed picture of every part!

### Ford 2.0L Engine Parts, Top End

Description	Part No.	Price
Heavy-Duty Cylinder Head Stud and 12-point Nut Kit	172-06-Kit	\$124.25
<i>Kit includes 10 each Studs, 12 Point Nuts, Lock Washers and a packet of assembly lube.</i>		
Intake Manifold, used (for Weber 32/36 DGV Carb)	172-09-Stk	\$299.99
Intake Valve	172-11	\$48.99
Exhaust Valve	172-12	\$56.99
Super-Duty Valve Spring Set (Ivey)	172-19	\$172.99
Valve Keeper, each (not pair - 2 required per valve)	172-14	\$1.69
Cam Spray bar	172-16	\$89.99
Bronze Valve Guide, .502 dia, .474 seal dia.	172-17	\$8.99
Valve Spring Shims, .06 thick	172-18-060	89¢
Stock Ford Camshaft and Eight Followers	172-21	\$469.99
Camshaft and Lifter Lubricant, 4 oz., Ford Motorsport	3312	\$8.49
Camshaft Thrust Plate	172-22	\$22.49
Camshaft Thrust Plate Screw, each	172-23	\$1.49
Cam Follower (rocker arm), each	172-24	\$79.99
Cam Follower Spring Clip, Heavy Duty, each	172-25-HD	\$5.99
Cam Follower Adjusting Stand Nut, each	172-27	\$3.99
Cam or Auxiliary Shaft Pulley	172-30	\$89.99
Front Bolt for Cam or Auxiliary Shaft, w/ locking patch	172-32-Bolt	\$1.59
Front Washer for Cam or Auxiliary Shaft	172-32-Washer	\$2.49
Cam or Auxiliary Shaft to Pulley Key, standard	172-33	\$1.99
Offset Cam Key, specify 1, 2, 3, 4 or 5°	172-34-( )	\$18.99
Offset Cam Key Set, includes 1 thru 5° keys	172-34-Set	\$90.99
Valve Cover Hold-downs, per set	172-43	\$10.99

### Stage 8 Locking Fastener Kit



Lose the safety wire - keep the header! The innovative **Stage 8 Locking Fastener System** uses a special 6-point bolt and a clip-on locking retainer to keep your exhaust header on tight. The clip-on retainer can be positioned so that the header tube will prevent the bolt from turning. Bolts, retainers, and E-clips are easily removed for service and are reusable indefinitely. Kit includes eight 6-point double hex head bolts measuring 8mm-1.25 x 25mm, 8 locking retainers, and 8 E-clips, enough for one Ford 2.0L ("Pinto") header.

Stage 8 Locking Fastener Kit for 2.0L Ford Header ..... Part No. ST8-6101 ... \$49.99