

Stock and Custom-Made Steering Racks

Whether you choose a stock rack off the shelf or a custom rack made to your specifications, you will get a top-quality unit engineered for smooth operation and long life. Unlike most racks which bend the rack towards the pinion to achieve optimum backlash, our design moves the pinion towards the rack in an eccentric housing. This has the obvious advantage of a much freer running rack and longer bearing life. Soft felt seals further enhance bearing life without adding friction. A safety backup buffer, positioned just clear of the rack, maintains tooth engagement under extreme loading without adding friction under normal operation. The housing is aluminum alloy. The pinion shaft has a 9/16 x 36 tooth spline to accept many standard universal joints or our rigid coupler listed below.

Stock Steering Rack **Part No. 1802** **\$979.00**

Our stock rack is based on the most commonly ordered custom rack dimensions.

A=18" B=13" C=10" D=1.5" T=1/2-20 (See drawing below.)

Custom-Made Steering Rack **Part No. 1800** **\$1,439.00**

See worksheet below or visit our website to order. Please allow 8 weeks for delivery of custom-made steering racks.

Rigid Coupler for 3/4 inch steering shaft **Part No. 1805-75** **\$89.99**

Attaches a 3/4" diameter steering shaft to a 9/16-36 splined pinion. One side has female 9/16-36 splines; the other has a 3/4" smooth bore. This is not a universal joint.

9 Tooth 12DP Steering Pinion **Part No. 1808-001** **\$154.99**

This pinion produces 2.54" of rack travel per full turn of the pinion. This is the standard pinion installed in our steering racks.



Stock Steering Rack, Part No. 1802

Dimensions of Stock Steering Rack:

- 18" Rack Bar Length • 13" Housing Length
- 10" Between Mounting Shoulders
- 1.5" Housing Diameter at Mounting Bosses
- 1/2-20 UNF Female Threads on Rack Bar Ends



Above: Rigid Coupler for 3/4 inch Steering Shaft Part No. 1805-75



Renault-Style Rack End Joint Assembly Part No. 1804-xx



Left: Replacement Parts for Renault-Style Rack End Joints Part No. 1804-Cup and Part No. 1804-Spring Sold individually

Right: Dallara-Style Compact Rack End Joints Part No. 1804-5/16-Compact Sold individually (two shown for illustration)



Steering Rack End Joints

Please Note: The following rack end joints do not fit our stock steering racks. Custom racks can be ordered to accept either the Renault or Dallara-style joints.

Renault-Style Rack End Joint, M12 x 1.5 **Part No. 1804-12mm** **\$117.99**

Renault-Style Rack End Joint, 3/8-24 UNF **Part No. 1804-3/8** **\$119.99**

Many British formula cars were originally built with steering racks which use these Renault-Style joints. Requires 22 x 1.5mm male threads on the steering rack.

Replacement Nylon Cup for Renault End Joint **Part No. 1804-Cup** **\$11.99**

Replacement Spring for Renault End Joint **Part No. 1804-Spring** **\$12.99**

Replacement M12 Ball Stud for Renault Joint **Part No. 1803-12mm** **\$81.99**

Dallara-Style Rack End Joint, 5/16-24 Male **Part No. 1804-5/16-Compact** **\$119.99**

These joints were designed for Dallara cars, but their compact, low-profile design makes them adaptable to other chassis. Requires 3/4-20 female threads on the steering rack.

Nylon Spacer - Lock Stop for Steering Rack **Part No. 1806-3mm** **\$10.99**

Nylon Spacer - Lock Stop for Steering Rack **Part No. 1806-10mm** **\$10.99**

These nylon spacers are used to fine-tune rack travel when Renault-Style or Dallara-Style rack end joints are installed. Spacers can be stacked to limit rack travel as needed.

Van Diemen Tie Rod End Inner Joint **Part No. 3065TSH-4-R** **\$40.99**

This special rod end has a 1/4" bore and a 5/16-24 male threaded shank. The small head (5/16" wide ball x 3/4" OD head) fits into the steering rack clevis on late-model Van Diemen formula cars. Right-hand thread only.



Left: Van Diemen Tie Rod Inner Joint Part No. 3065TSH-4-R

Custom-Made Steering Rack Worksheet

Use this worksheet to order your custom steering rack. You can also visit our website for an interactive order form to guide you through the ordering process.

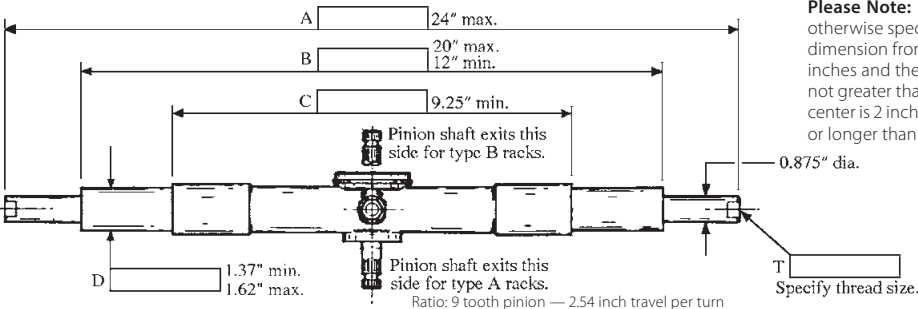

Please Note: The pinion shaft is in the center of the rack housing unless otherwise specified. A small amount of offset can be provided as long as the dimension from the pinion to the short end of the housing is not less than 6 inches and the dimension from the pinion to the long end of the housing is not greater than 10 inches. This means that the maximum pinion offset from center is 2 inches for a 16 inch housing length. If the housing length is shorter or longer than 16 inches, the maximum offset will be less than 2 inches.

Car Make	
Car Model	
Rack Type (A or B)	

Type A: More suited for mounting in front of a bulkhead.
Type B: More suited for mounting behind a bulkhead.

STEERING

Anti-heat° Heat Sink Compound



- Heat barrier
- Prevents warping
- Prevents discoloration

Anti-heat° is great for protecting the bearings and boots of universal joints during welding!

Anti-heat° protects metals and other materials from the heat of welding, brazing or soldering. It absorbs surface heat to prevent buckling or warping in thin materials. It also prevents discoloration, blistering, and cracking. It's fast and easy to apply directly from the caulking tube. Safe to use on any vertical, horizontal or overhead surface. Anti-heat° is non-toxic, harmless to the skin and odorless. Cleanup is easy – just wipe off the excess and wash with water.

Anti-heat° Protective Compound, 12 ounce caulking gun tube **Part No. 3389-12 oz** **\$25.49**